

Twin Conditioner

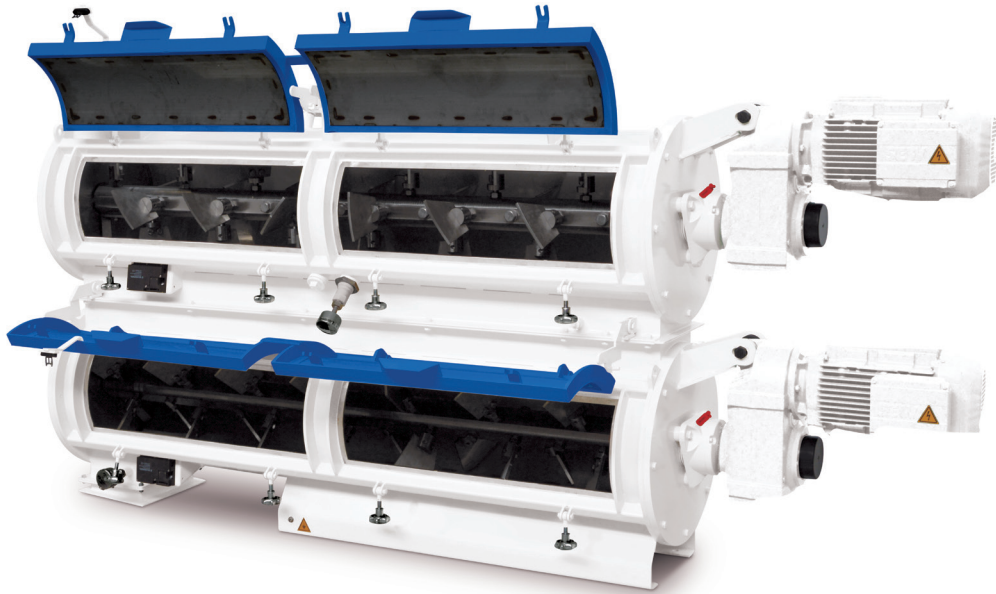

General

The details in development and engineering make the difference in this Twin Conditioner. Generously sized paddles, adjustable in both height and pitch, create a homogeneous mixture and an hygienic process

Advantages

- » a doubling of the retention time of the product inside the conditioner in comparison with a single conditioner
- » homogeneous mixing and hygienic process
- » optimum absorption of steam and liquids
- » robust construction of the housing
- » easy to clean
- » longer maintenance intervals
- » simple design

Features

- » 2 conditioners placed on top of each other
- » each mixer housing in AISI 304, base plate construction in heavy duty steel
- » solid mixer shafts in AISI 304 with interchangeable paddles, adjustable in both height and pitch.
- » paddle holders in AISI 304, paddles in Hardox
- » built-in scrapers at endplates
- » stuffing box sealings on mixer shafts
- » closed shaft bearings on spacers outside the housings
- » each mixer shaft directly driven by gear motor. Suitable for frequency control. (Frequency converters not included.)
- » large inspection doors with safety switch
- » 2x temperature sensor PT 100
- » top mixer housing with 1 steam inlet 3" and 2 liquid inlets 1½"
- » electric heat tracing system, insulated with rock-wool (optional)

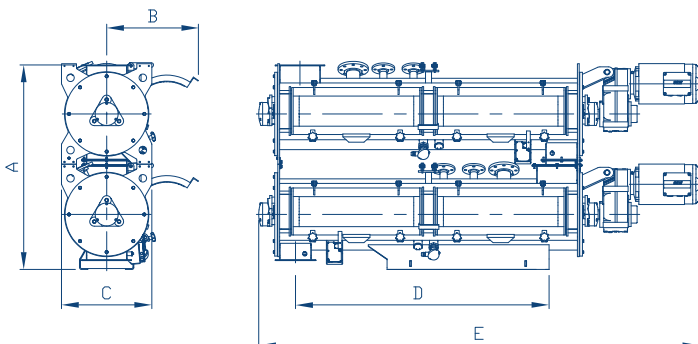

Type	Capacity (t/h)	Dimensions (in mm)					Motor-power (kW)
		A	B	C	D	E	
450 x 2.000	15	1.357	605	600	1.683	2.925	2 x 9,2
500 X 2.500	20	1.365	645	660	2.050	3.575	2 x 15
700 X 3.000	30	1.914	885	860	2.830	4.150	2 x 18,5

FEEDER SCREW

CONDITIONER

TCS

BOA COMPACTOR

PELLET MILL

COOLER

CRUMBLER

ROTOR SIFTER

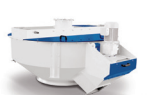
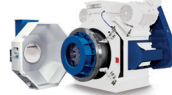

PTN produces and develops high-quality, reliable machines. It strives to provide its customers with the following benefits through its products:

- » Higher yields.
- » Lower energy consumption.
- » Low maintenance requirements.
- » Access to state-of-the-art technology.

As a globally operating, specialized manufacturer of pelletisers and related machinery it is our ambition to expand to become the most respected professional OEM (Original Equipment Manufacturer).

Our strategy for achieving this ambition is to:

- » Expand and consolidate the global network of professional sales and service points.
- » Create a virtual and real image of professionalism, quality and innovation as well as a high level of standardisation and digital accessibility for strategic partners.
- » Transform technology, know-how and competences into technical and commercial added value.
- » Generate stable growth in sales and profit.



Galvaniweg 29
5482 TN SCHIJNDEL
The Netherlands

T +31 (0)73 54 98 472
info@ptn.nl
www.ptn.nl